

## Emission of electromagnetic disturbance

**Test Report No.** : FCC2009-0025  
**Equipment** : Digital Video Recorder  
**Name of basic model** : 9116G4  
**Family model** : None  
**Manufacturer** : Win4net Co., Ltd.  
**Applicant** : Win4net Co., Ltd.  
**Tested date** : 2009. 03. 28  
**Receipt of date** : 2009. 03. 27.  
**Testing Environment** : Temperature: (17.1) °C, Relative Humidity: (37.4) % R.H.,  
Atmospheric pressure : (100.5) kPa  
**Issued date** : 2009. 04. 06.  
**Test results** : Pass  
**Test Standards** : FCC Part 15 Subpart B  
/ Class B digital devices & peripherals & external switching power supplies

<b>Affirmation</b>	Measurements performed by Title : Manager Name: Kim, Young-Sik (Signature)	Approved by Title : Manager Name : Hur, Gweon (Signature)
--------------------	--	---



EMC Research Institute

2009. 04. 06.

## CONTENTS

### 1. CLIENT INFORMATION

### 2. LABORATORY INFORMATION

### 3. EQUIPMENT UNDER TEST INFORMATION (EUT)

- 3.1. Identification of the EUT
- 3.2. Additional information about the EUT
- 3.3. Peripheral equipment

### 4. TEST SPECIFICATIONS

- 4.1. Standards

### 5. TEST RESULTS SUMMARY

- 5.1 Test result
- 5.2 General performance criteria
- 5.3 CONTINUOUS DISTURBANCE VOLTAGE AT MAIN TERMINALS
  - 5.3.1 Operating environment
  - 5.3.2 Test set-up and test procedures
  - 5.3.3 Operation Conditions
  - 5.3.4 Test instrument
  - 5.3.5 Test results
- 5.4 RADIATED DISTURBANCE
  - 5.4.1 Operating environment
  - 5.4.2 Test set-up
  - 5.4.3 Operating conditions
  - 5.4.4 Test instrument
  - 5.4.5 Test results

### 6. PRODUCT PHOTOGRAPHS

- 6.1. Front Photograph of EUT
- 6.2. Rear Photograph of EUT

## 1. CLIENT INFORMATION

The EUT has been tested by request of :

Company : Win4net Co., Ltd.  
Address : Win4net Building, 1027-5, Hogye-dong, Dongan-gu, Anyang-si, Gyeonggi-do, Korea  
Name of contact : Jeong, Ji-Han  
Telephone : +82-31-455-8600  
Facsimile : +82-31-455-8601

## 2 LABORATORY INFORMATION

The 10 m Semi-anechoic chamber and/or EMC facilities are used for these testing.  
These facilities were accredited by KOLAS, EK, MIC of Korea and FCC of USA.

### Address

EMC RESEARCH INSTITUTE  
66-6, Jeil-Ri, Yangji-Myun, Cheoin-Gu, Yongin-Si, Gyeonggi-Do, Korea  
Telephone No. : + 82-31-679-9600  
Facsimile No. : + 82-31-336-1184

### Registered No.

KOLAS : 111  
EK : J  
MIC, FCC(DoC) : KR0030  
FCC Filing No. : 302567

## 3 EQUIPMENT UNDER TEST INFORMATION (EUT)

### 3.1. Identification of the EUT

Type of equipment : Digital Video Recorder  
Model name : 9116G4

### Manufacturer Address

Company : Win4net Co., Ltd.  
Address : Win4net Building, 1027-5, Hogye-dong, Dongan-gu, Anyang-si, Gyeonggi-do, Korea  
Telephone : +82-31-455-8600  
Facsimile : +82-31-455-8601  
Country of origin : KOREA  
Test voltage : AC 110 V, 60 Hz

**3.2. Additional information about the EUT**

Class B

**3.3. Peripheral equipment**

Defined as equipment needed for correct operation of the EUT.

Description	Model No.	Serial No.	Manufacturer
Mouse	-	-	Microsoft
Mouse	Com-E1	-	Quick
Keyboard	TRI-270	107013318	Solid Year Co., Ltd
Keyboard	SDM4510UH	4M020619	Samsung Electronics
Monitor	750S	9017HICKCC8158	Samsung Electronics
Headset	Actto	-	-
Color pattern generator	PM5418TDSI	LO 612359	PHILIPS

**4 TEST SPECIFICATIONS**

**4.1. Standards**

The standards for a EUT are the following:

Standard	Remark
ANSI 63.4: 2003	Methods of Measurement of Radio-Noise Emission from Low-Voltage Electrical and Electronic Equipment in the range of 9 kHz to 40 GHz

**5 TEST RESULTS SUMMARY**

**5.1 Test results**

The results in this report apply only to sample tested:

Standards	Test items / Frequency	Result
ANSI 63.4: 2003	1. Main Terminal disturbance voltage	Pass
	2. Radiated disturbance	Pass

## 5.2 CONTINUOUS DISTURBANCE VOLTAGE AT MAIN TERMINALS

### 5.2.1 Operating environment

Test location : Shield room

### 5.2.2 Test set-up and test procedures

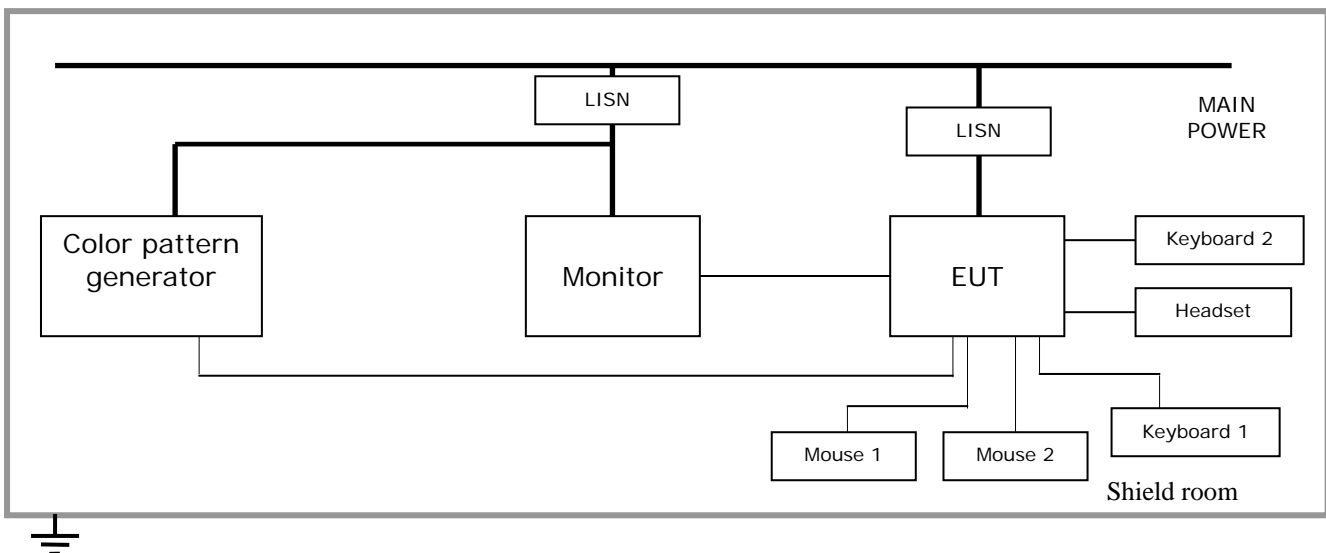

The conducted disturbance at mains terminals was measured with the equipment under Test(EUT) in a shield room. The EUT was connected to an artificial mains Network(LISN) placed on the floor. The EUT was placed on non-metallic table 0.8 m above the metallic, grounded floor. The distance to other metallic surface was at least 0.8 m. Amplitude measurements were performed with a quasi-peak detector and an average detector.

### 5.2.3 Operation condition

The EUT was performed with recording and playing the signal of audio and video.

### 5.2.4 Test instrument

Instrument	Model No	Serial No.	Makers	Used
Test receiver	ESCS30	830986/015	R&S	O
L.I.S.N.	ESH3-Z5	100030	R&S	O
	ESH3-Z5	100031	R&S	O
Shield room	8 m/W × 6 m/L × 3.3 m/H		-	O

### 5.2.5 Test results

Tested Date : 2009. 03. 28.

An overview sweep performed with peak detector & average detectors are included in the report as test reports.

#### Result : Pass

- The measured emissions level of the EUT met the requirement of specified limit.
- Conducted disturbance(150 kHz – 30 MHz) :  $\pm 3.60$  dB (Confidence level 95 %,  $k=2$ )

TEST GRAPH

CONTINUOUS DISTURBANCE VOLTAGE

EUT: 9116G4  
 Manuf: WIN4NET  
 Op Cond: L  
 Operator: ERI  
 Date: 28. Mar 09 15:32

Scan Settings (2 Ranges)

Frequencies			Receiver Settings				
Start	Stop	Step	IF BW	Detector	M-Time	Atten	Preamp
150k	3M	3k	9k	PK+AV	5ms AUTO	LN	ON
3M	30M	10k	9k	PK+AV	1ms AUTO	LN	ON

Transducer No. Start Stop Name  
 7 9k 30M ESH3\_Z5

Final Measurement: x QP / + AV  
 Meas Time: 1 s  
 Subranges: 16  
 Acc Margin: 30dB

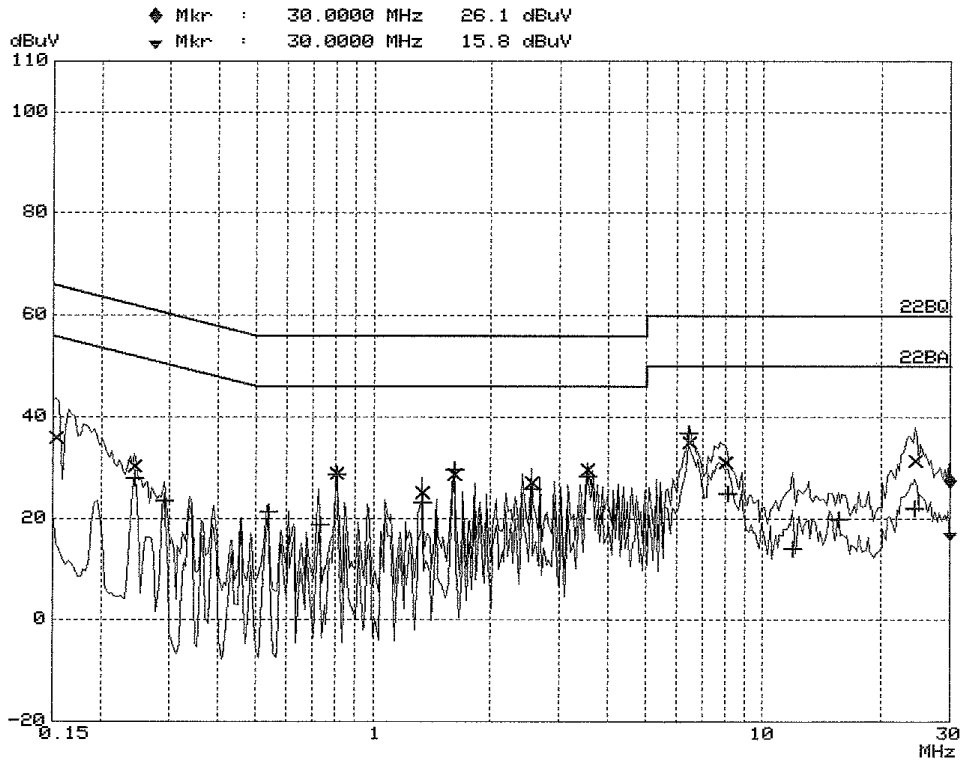

CONTINUOUS DISTURBANCE VOLTAGE

EUT: 9116G4  
 Manuf: WIN4NET  
 Op Cond: L  
 Operator: ERI  
 Date: 28. Mar 09 15:32

Final Measurement Results:

Indicated Phase/PE shows Configuration of max. Emission

Frequency MHz	QP Level dBuV	Delta Limit dB	Phase -	PE -
0.15300	35.9	-29.9	L1	gnd
0.24300	30.3	-31.6	N	gnd
0.80400	28.9	-27.0	N	gnd
1.33800	25.3	-30.6	L1	gnd
1.60800	28.9	-27.1	N	gnd
2.54400	27.1	-28.8	N	gnd
3.55000	29.6	-26.3	N	gnd
6.46000	35.0	-24.9	L1	gnd
8.00000	31.2	-28.7	L1	gnd
24.43000	31.5	-28.4	L1	gnd

Frequency MHz	AV Level dBuV	Delta Limit dB	Phase -	PE -
0.24300	28.1	-23.9	L1	gnd
0.29100	23.6	-26.8	N	gnd
0.53700	21.4	-24.5	L1	gnd
0.72900	18.9	-27.0	L1	gnd
0.80400	28.8	-17.1	N	gnd
1.33800	23.3	-22.6	L1	gnd
1.60800	29.7	-16.2	N	gnd
2.54700	26.0	-19.9	L1	gnd
3.55000	28.4	-17.5	N	gnd
6.43000	36.8	-13.1	N	gnd
8.10000	25.0	-24.9	N	gnd
11.88000	14.1	-35.8	N	gnd
15.53000	20.0	-29.9	N	gnd
24.31000	22.1	-27.8	L1	gnd

\* limit exceeded

< LINE : LIVE >

Uncertainty :  $U = -3.60 \text{ dB} \sim +3.60 \text{ dB}$  (confidence level 95 %,  $k = 2$ )

CONTINUOUS DISTURBANCE VOLTAGE

EUT: 9116G4  
 Manuf: WIN4NET  
 Op Cond: N  
 Operator: ERI  
 Date: 28. Mar 09 15:32

Scan Settings (2 Ranges)

Frequencies			Receiver Settings				
Start	Stop	Step	IF BW	Detector	M-Time	Atten	Preamp
150k	3M	3k	9k	PK+AV	5ms	AUTO LN	ON
3M	30M	10k	9k	PK+AV	1ms	AUTO LN	ON

Transducer No. Start Stop Name  
 7 9k 30M ESH3\_Z5

Final Measurement: x QP / + AV  
 Meas Time: 1 s  
 Subranges: 16  
 Acc Margin: 30dB

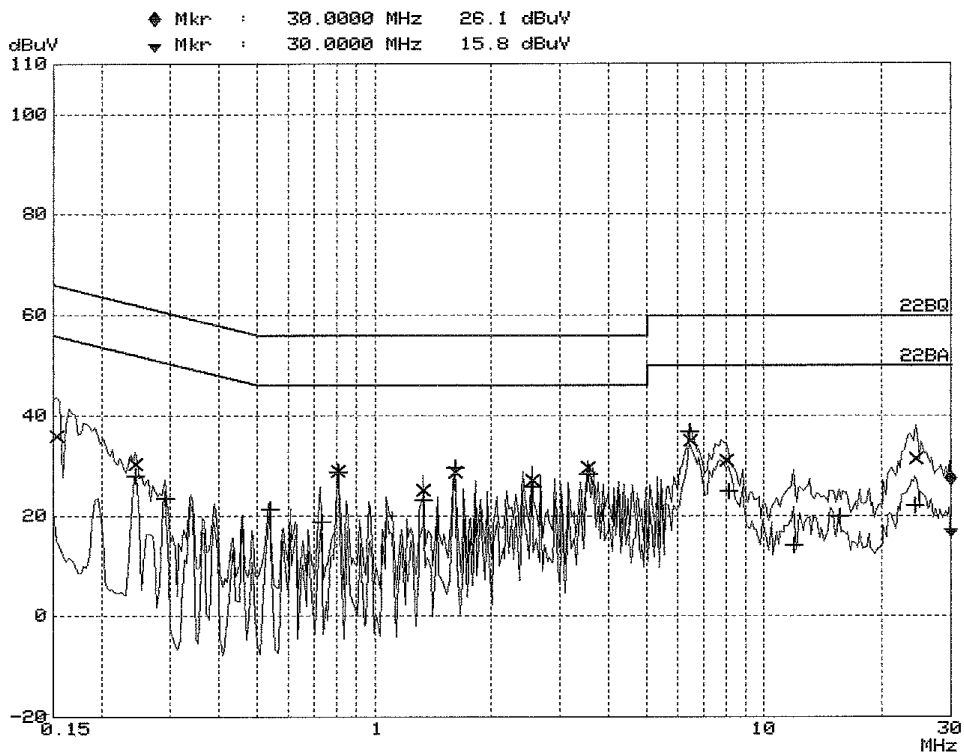

CONTINUOUS DISTURBANCE VOLTAGE

EUT: 9116G4  
 Manuf: WIN4NET  
 Op Cond: N  
 Operator: ERI  
 Date: 28. Mar 09 15:32

Final Measurement Results:

Indicated Phase/PE shows Configuration of max. Emission

Frequency MHz	QP Level dBuV	Delta Limit dB	Phase -	PE -
0.15300	35.9	-29.9	L1	gnd
0.24300	30.3	-31.6	N	gnd
0.80400	28.9	-27.0	N	gnd
1.33800	25.3	-30.6	L1	gnd
1.60800	28.9	-27.1	N	gnd
2.54400	27.1	-28.8	N	gnd
3.55000	29.6	-26.3	N	gnd
6.46000	35.0	-24.9	L1	gnd
8.00000	31.2	-28.7	L1	gnd
24.43000	31.5	-28.4	L1	gnd

Frequency MHz	AV Level dBuV	Delta Limit dB	Phase -	PE -
0.24300	28.1	-23.9	L1	gnd
0.29100	23.6	-26.8	N	gnd
0.53700	21.4	-24.5	L1	gnd
0.72900	18.9	-27.0	L1	gnd
0.80400	28.8	-17.1	N	gnd
1.33800	23.3	-22.6	L1	gnd
1.60800	29.7	-16.2	N	gnd
2.54700	26.0	-19.9	L1	gnd
3.55000	28.4	-17.5	N	gnd
6.43000	36.8	-13.1	N	gnd
8.10000	25.0	-24.9	N	gnd
11.88000	14.1	-35.8	N	gnd
15.53000	20.0	-29.9	N	gnd
24.31000	22.1	-27.8	L1	gnd

\* limit exceeded

< LINE : NEUTRAL >

Uncertainty :  $U = -3.60 \text{ dB} \sim +3.60 \text{ dB}$  (confidence level 95 %,  $k = 2$ )

### 5.3 RADIATED DISTURBANCE

#### 5.3.1 Operating environment

Test location : 10 m Semi-anechoic chamber

#### 5.3.2 Test set-up

All readings are quasi-peak unless stated otherwise. The half-wave dipole antenna was tuned to the frequency found during Preliminary radiated measurements. The EUT, support equipment and Interconnecting cables were re-configured to the set-up to produce the Maximum emission for the frequency and were placed on top of a 0.8 m High non-metallic 1 m × 1.5 m table. The EUT, support equipment, and interconnecting cables were re-arranged and manipulated to maximize each radiated emission. The turntable containing the system was rotated the antenna height was varied 1 m to 4 m and stopped at the azimuth or height producing the maximum emission. And this device (EUT) was tested in 3 orthogonal planes. The antenna measured both horizontal and vertical polarization.

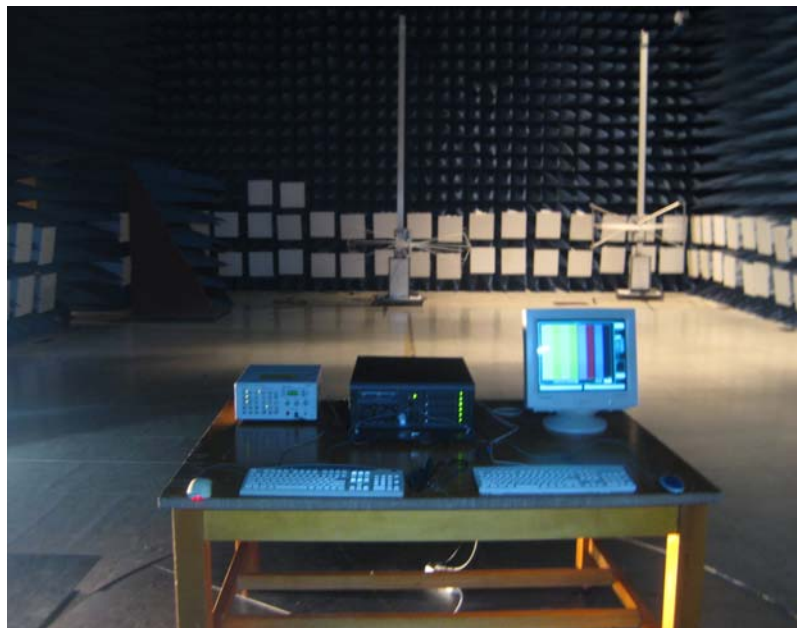
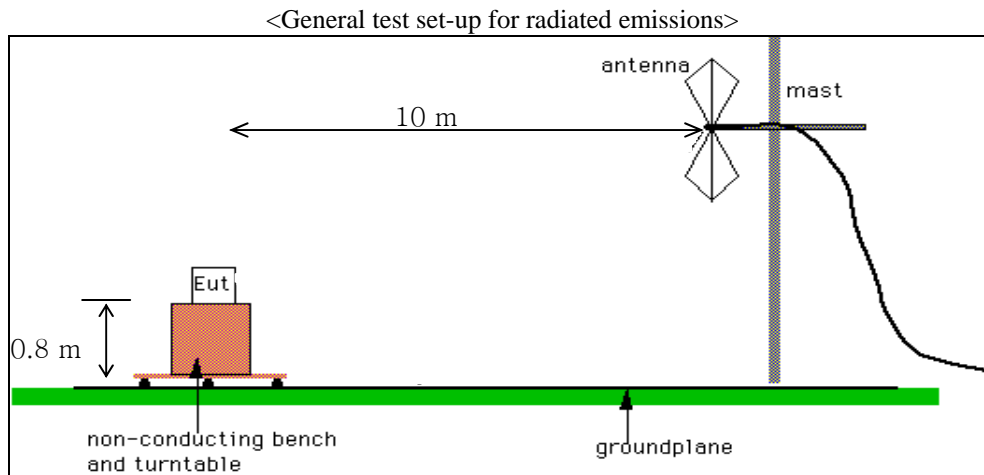

**5.3.3 Operation Conditions**

The EUT was performed with recording and playing the signal of audio and video.

**5.3.4 Test instrument**

Instrument	Model No.	Serial No.	Makers	Used
Antenna Mast	MA240	-	HD	O
Turn Table	DT430S	-	HD	O
Spectrum	E7402A	US40240261	Agilent	O
Test receiver	ESCS30	830986/015	R&S	O
BI LOG Antenna	VULB9156	2041	Schwarzbeck	O

**5.3.5 Test results**

Date of test : 2009. 03. 28.

Freq (MHz)	Reading (dBμV)	Ant pol	AF (dB/m)	CL (dB)	Result [A] (dBμV/m)	Limit [B] (dBμV/m)	Margin [A]-[B] (dB)
36.00	10.0	V	9.3	1.9	21.2	30	8.8
49.12	6.3	V	10.2	4.1	20.5	30	9.5
122.04	8.3	V	11.0	2.5	21.8	30	8.2
163.90	9.3	V	11.6	2.8	23.7	30	6.3
188.08	13.3	H	10.2	3.0	26.5	30	3.5
192.05	11.6	V	10.1	3.0	24.8	30	5.2
296.02	9.7	H	13.1	3.8	26.6	37	10.4
351.07	7.8	H	14.2	4.1	26.1	37	10.9
364.55	11.4	H	14.4	4.2	30.0	37	7.0
405.79	11.8	H	15.1	4.6	31.5	37	5.5
457.99	8.5	H	16.7	5.0	30.2	37	6.8
487.94	9.3	H	17.2	5.0	31.6	37	5.5

\* Meter reading: *Include Antenna Factor and cable loss*

\* Receiving Antenna Mode: *Horizontal, Vertical*

\* Test distance : 10 m

**Result : Pass**

The measured emissions level of the EUT have found the below of the specified limit.

- Radiated disturbance( 30 MHz – 200 MHz) : ± 4.26 dB (Confidence level 95 %, k =2)
- Radiated disturbance ( 200 MHz – 1 000 MHz) : - 4.10 dB – +3.94 dB (Confidence level 95 %, k =2)
- Radiated disturbance ( 1 000 MHz – above): Under consideration by CISPR 16-4-2:2003

## 6 PRODUCT PHOTOGRAPHS

### 6.1. Front Photograph of EUT



### 6.2. Rear Photograph of EUT

